

www.pintsch Tiefenbach.de

# Railway Signalling Technology.

## Switching the points. Safely and reliably.

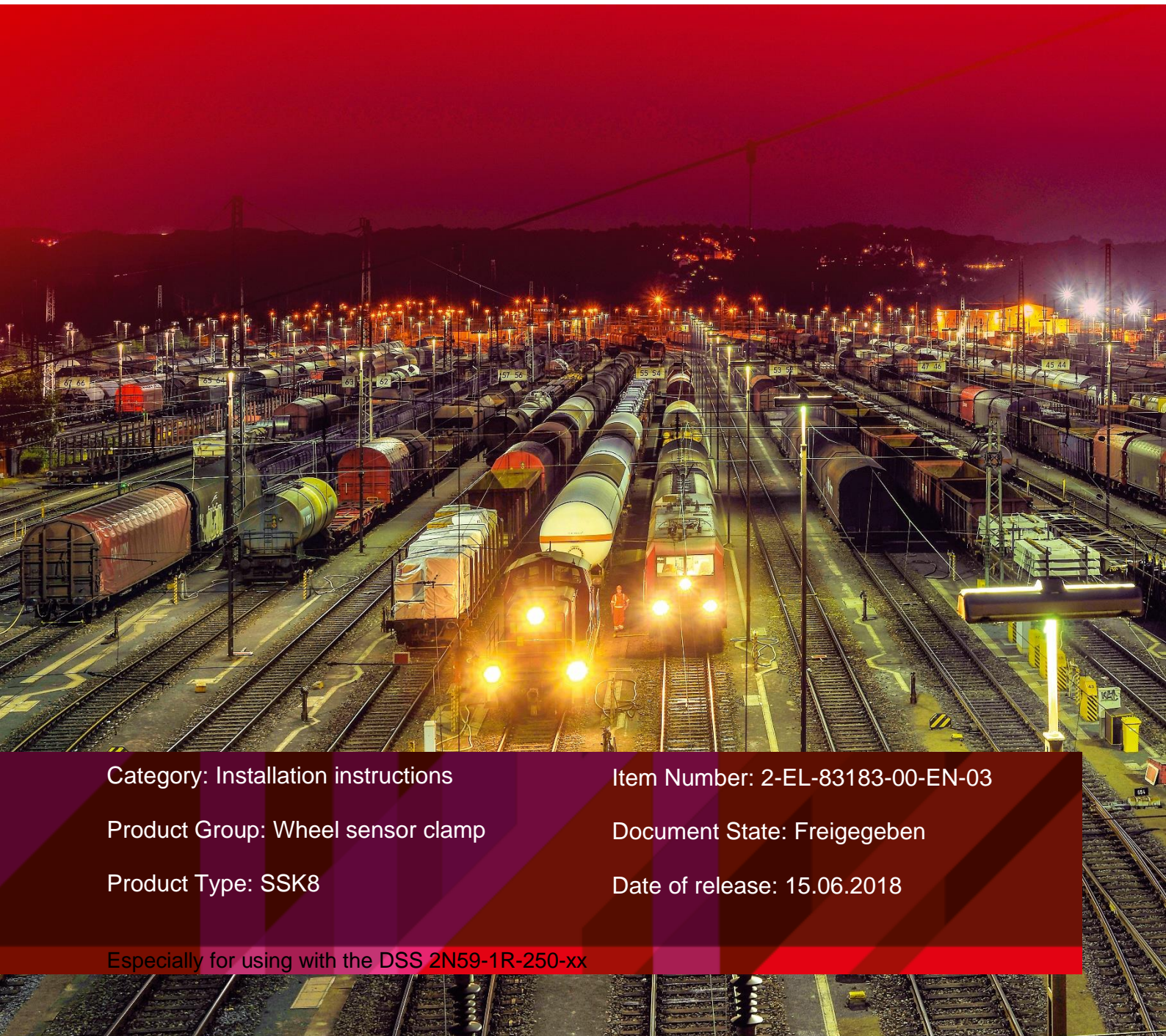

Category: Installation instructions

Item Number: 2-EL-83183-00-EN-03

Product Group: Wheel sensor clamp

Document State: Freigegeben

Product Type: SSK8

Date of release: 15.06.2018

Especially for using with the DSS 2N59-1R-250-xx

## 1 Table of contents

<b>1</b>	<b>Table of contents</b> .....	<b>2</b>
1.1	List of tables .....	2
1.2	List of figures .....	2
1.3	Revision history .....	3
1.4	Index of abbreviations .....	3
1.5	Safety Notes .....	3
<b>2</b>	<b>Usage</b> .....	<b>4</b>
<b>3</b>	<b>Assembly</b> .....	<b>4</b>
3.1	Installation location .....	4
3.2	Installation of the SSK at the rail .....	5
3.3	Installation of the DSS at the mounting plate .....	6
3.4	Installation of the mounting plate at the SSK .....	7
3.5	Subsequent adjustment of the DSS .....	7
3.6	Installation drawing.....	8
3.7	Rail profile list .....	9
<b>4</b>	<b>Maintenance of the SSK8</b> .....	<b>12</b>

### 1.1 List of tables

Table 1:	List of changes.....	3
Table 2:	Index of abbreviations .....	3
Table 3:	safety notes .....	3
Table 4:	excerpt from the rail profile list.....	12

### 1.2 List of figures

Figure 1:	Overview SSK8 .....	4
Figure 2:	installation location sleeper bay .....	5
Figure 3:	backing device fixation .....	5
Figure 4:	Fastening of the SSK at the rail.....	5
Figure 5:	front view DSS at the mounting plate .....	6
Figure 6:	various spacer plates .....	6
Figure 7:	distance DSS to the rail web .....	6
Figure 8:	spacer plate offset .....	6
Figure 9:	Corrugation of the mounting plate .....	7
Figure 10:	Measure Y (X) with gauge SAHL 2 .....	7
Figure 11:	Installation drawing.....	8

### 1.3 Revision history

Version	Prepared by	Date	Checked by	Date	Short description of changes
00	S. Dünnwald	06.04.2017	J. Schlatter T. Wyrwich	06.04.2017 07.04.2017	First edition
01	S. Dünnwald	14.08.2017	R. Wiengarten	17.08.2017	Assembly Drawing Text in German, added table for the value S
02	S. Dünnwald	17.04.2018	T. Wyrwich	03.05.2018	applied 2018 layout 2018; chap. 4 (Maintenance) added4
03	S. Dünnwald	14.05.2018	J. Schlatter	14.05.2018	Adjustment of chap. 3.3, the assembly drawing figure 11 and table 4: excerpt from the rail profile list in chap. 3.73.3Figure 11: Installation Drawing11Table 4: Excerpt From The Rail Profile List43.7

Table 1:List of changes

### 1.4 Index of abbreviations

Abbreviation	Explanation
DSS	Double wheel sensor
SAHL 2	Wear of rail gauge
SSK	Wheel sensor clamp

Table 2: Index of abbreviations

### 1.5 Safety Notes

This section explains the safety-related symbols and signal words used throughout this document. Please note that it is imperative that these safety precautions be observed to prevent damage to property or injury to persons.





Symbol	Signal word	Explanation
	Recommendation	This symbol and/or signal word indicates that useful recommendations are given.
	Note	This symbol and/or signal word makes you aware of possible problems.
	Caution	This symbol and/or signal word indicates a hazardous situation which could result in minor injury or severe damage to property.
	Warning	This symbol and/or signal word indicates a hazardous situation which could result in serious injury or death.
	Danger	This symbol and/or signal word indicates an imminent hazardous situation which, with certainty, will result in serious injury or death.

Table 3: safety notes3

Category: Installation instructions  
Group/Type: Wheel sensor clamp SSK8  
Item Number: 2-EL-83183-00-EN-03





## 2 Usage

A wheel sensor clamp is used to attach a DSS to a rail without drilling. It is mounted on the rail underneath the rail foot so that the DSS is installed in its installation position.

## 3 Assembly

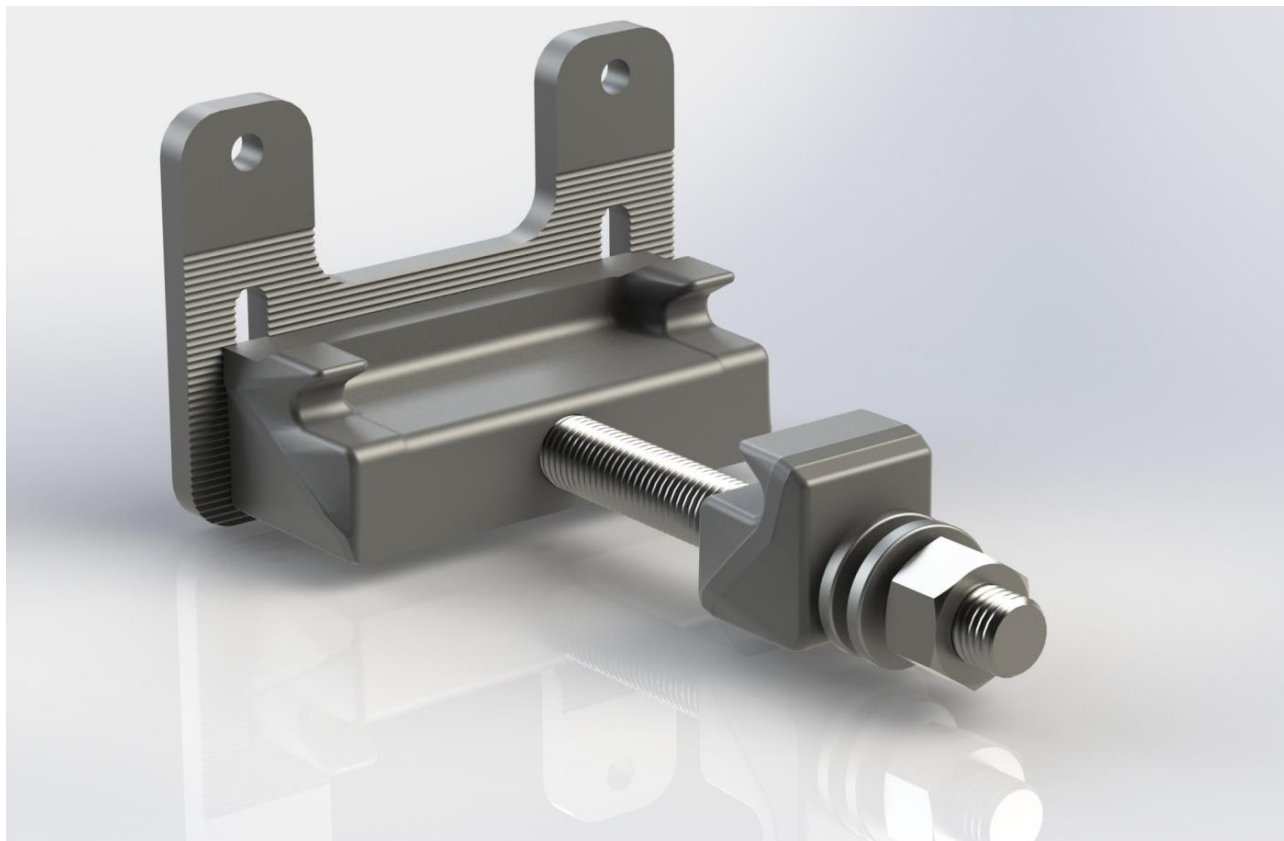

Figure 1: Overview SSK81

### 3.1 Installation location

- If necessary, remove the ballast at the installation site
- The rail foot must be cleaned before installing the SSK



The rail foot must be free from coarse dirt and unevenness at the installation site!

- The SSK must be attached to the rail in such a way that the installed DSS is located on the inner arch in the track.



The intended installation location can only be located within a sleeper bay.

This bay must correspond to the following sketch.

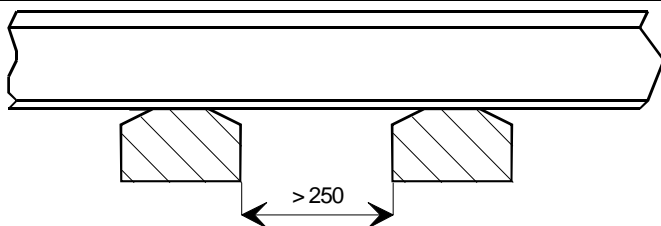

Figure 2: installation location sleeper bay2

### 3.2 Installation of the SSK at the rail

- To fasten the SSK to the rail, unscrew the hexagon nut (SW36), remove the safety ring and the counter holder
- The M24 threaded rod is positioned from the track interior underneath the rail
- Install the counter holder
- The rail foot must lie between the keyways
- Use the safety ring and the hexagon nut to secure the counter holder
- Tightening torque 135 ( $\pm$  15) Nm



Figure 3: backing device fixation 3

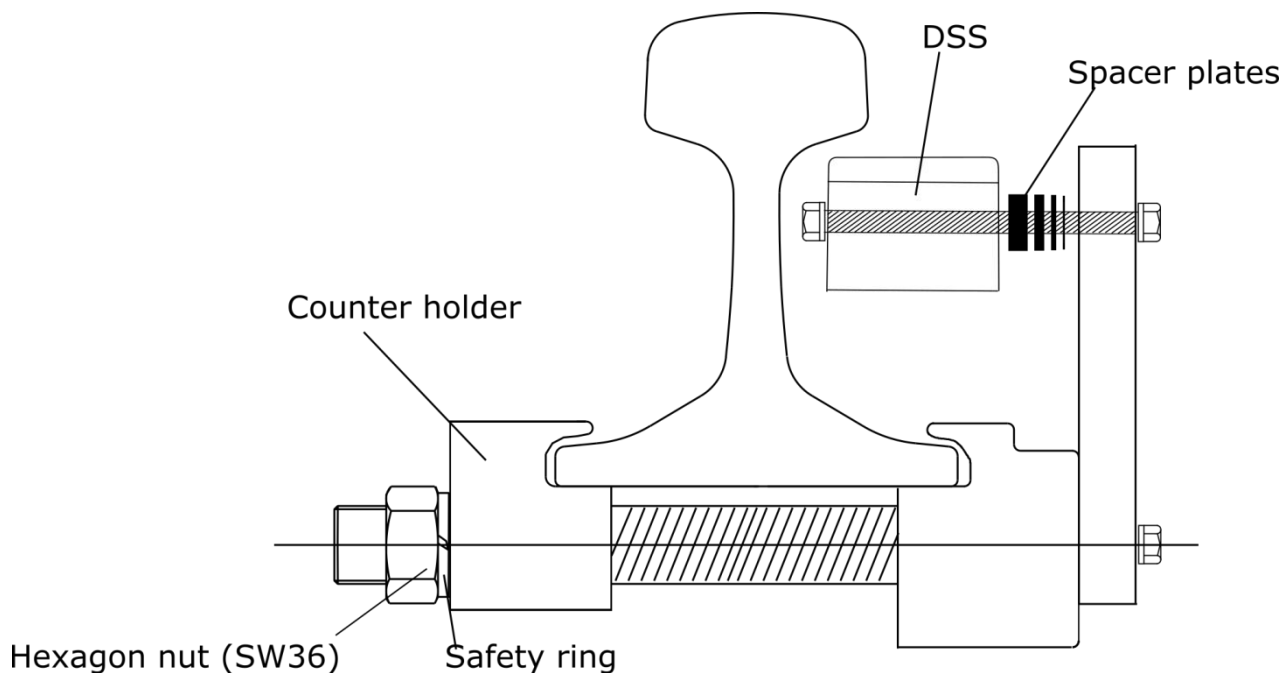

Figure 4: Fastening of the SSK at the rail4



When fastening the claw, make sure that both keyways are not misaligned and clamp the rail foot evenly. Only the proper fit of the claw on the rail guarantees trouble-free operation of the DSS!

### 3.3 Installation of the DSS at the mounting plate

- When installing the DSS on a SSK for the first time, it is advisable to loosen the mounting plate on the two lower M12 hexagon nuts and then disconnect it from the SSK.
- Position the DSS on the inside of the mounting plate in such a way that the label remains legible on the DSS.
- Insert the two M12 x 130 hexagonal screws from the back of the DSS through the through holes provided for this purpose.
- Depending on the distance between the DSS and the rail, spacer plates are positioned between the DSS and the inner side of the mounting plate.
- There are spacer plates with three different widths (cf. figure 6):
  - 1 mm
  - 2 mm
  - 4 mm
- How many spacer plates have to be used depends on following aspects:
  - Type of DSS
  - Rail profile
- In a rail profile list (cf. table 4: excerpt from the rail profile list in chap. 3.7) these parameters are listed  
Table 4: Excerpt From The Rail Profile List
- In order to measure the required distance (S) between the DSS front and the rail web, it is recommended to use a SAHL 2 as shown in figure 7  
Figure 7: distance DSS to the rail web
- If more than one spacer plate is used, it is advisable to mount the plates onto the long hexagon bolts opposite from their openings (cf. Figure 8: spacer plate offset)
- On the front of the mounting plate the M12 x 130 hexagon bolts are screwed together with self-locking M12 nuts in the upper holes with a torque of 50 ( $\pm 5$ ) Nm. For this, it is recommended to use a wrench, which can be used to counter the hexagon nuts on the back of the DSS.

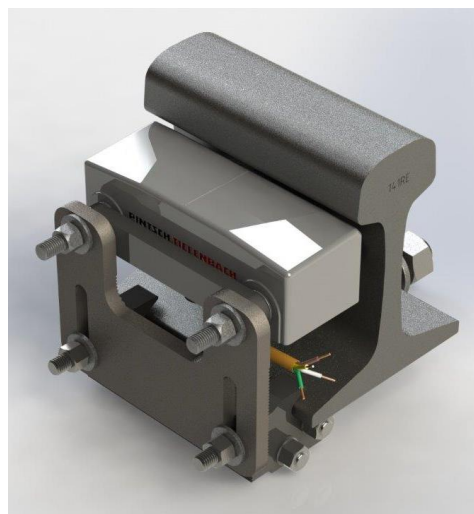

Figure 5: front view DSS at the mounting plate5



Figure 6: various spacer plates6



Figure 7: distance DSS to the rail web7



Figure 8: spacer plate offset8

### 3.4 Installation of the mounting plate at the SSK

- The mounting plate with the mounted DSS is guided through the long holes to the two threaded studs of the SSK
- The plate is hand-tightened with 2x2 Nord-Lock wedge lock washers and M12 hexagonal nuts

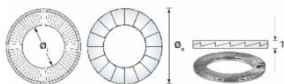

- The mounting plate has on its inside a corrugation with a 1.5 mm grid (cf. figure 9). This allows the adjustment of the height positioning of the DSS in relation to the upper side of the rail head. Figure 9: Corrugation of the mounting plate

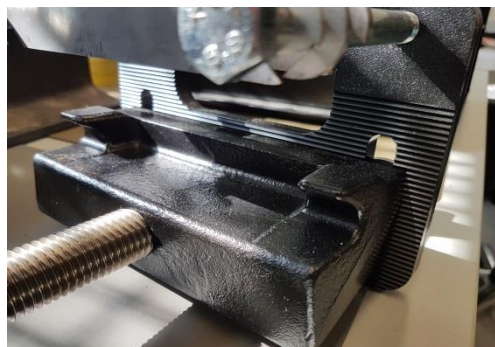

Figure 9: Corrugation of the mounting plate9



Due to the grid spacing of 1.5 mm, the best fit DSS position must be chosen, which corresponds to the theoretical dimension for the required switching distances of the DSS!

- The distance Y [X when rail is worn](cf. figure 10 and figure 11) from the upper edge of the DSS to the upper edge of a new rail is 45 mm ( $\pm 1$  mm) for each DSS type and can be measured with a SAHL 2 (taking care that the gauge is positioned rectangular from the highest point on the upper side of the rail) Figure 10: Measure Y (X) with gauge SAHL 2 Figure 11: Installation Drawing11
- When the height is adjusted, the M12 hexagon nuts are tightened with a torque of 50 Nm ( $\pm 5$ )

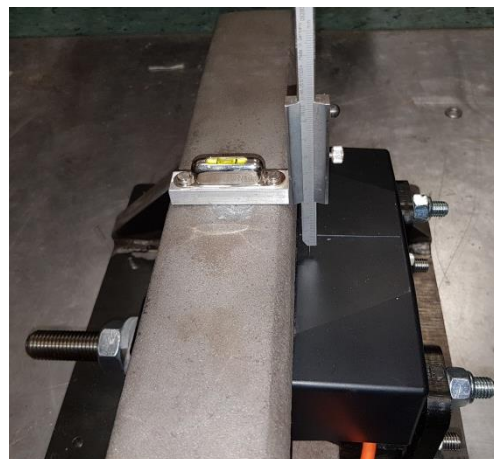

Figure 10: Measure Y (X) with gauge SAHL 210



The function test and setting of the switching distance is to be taken from the corresponding installation instructions of the respective DSS.

### 3.5 Subsequent adjustment of the DSS

If it is necessary to adjust the DSS after its initial assembly at the SSK without completely dismantling it, the self-locking M12 nuts must be released again.

For this, it is recommended to use a wrench, which can be used to counter the hexagon nuts on the back of the DSS.



### 3.6 Installation drawing

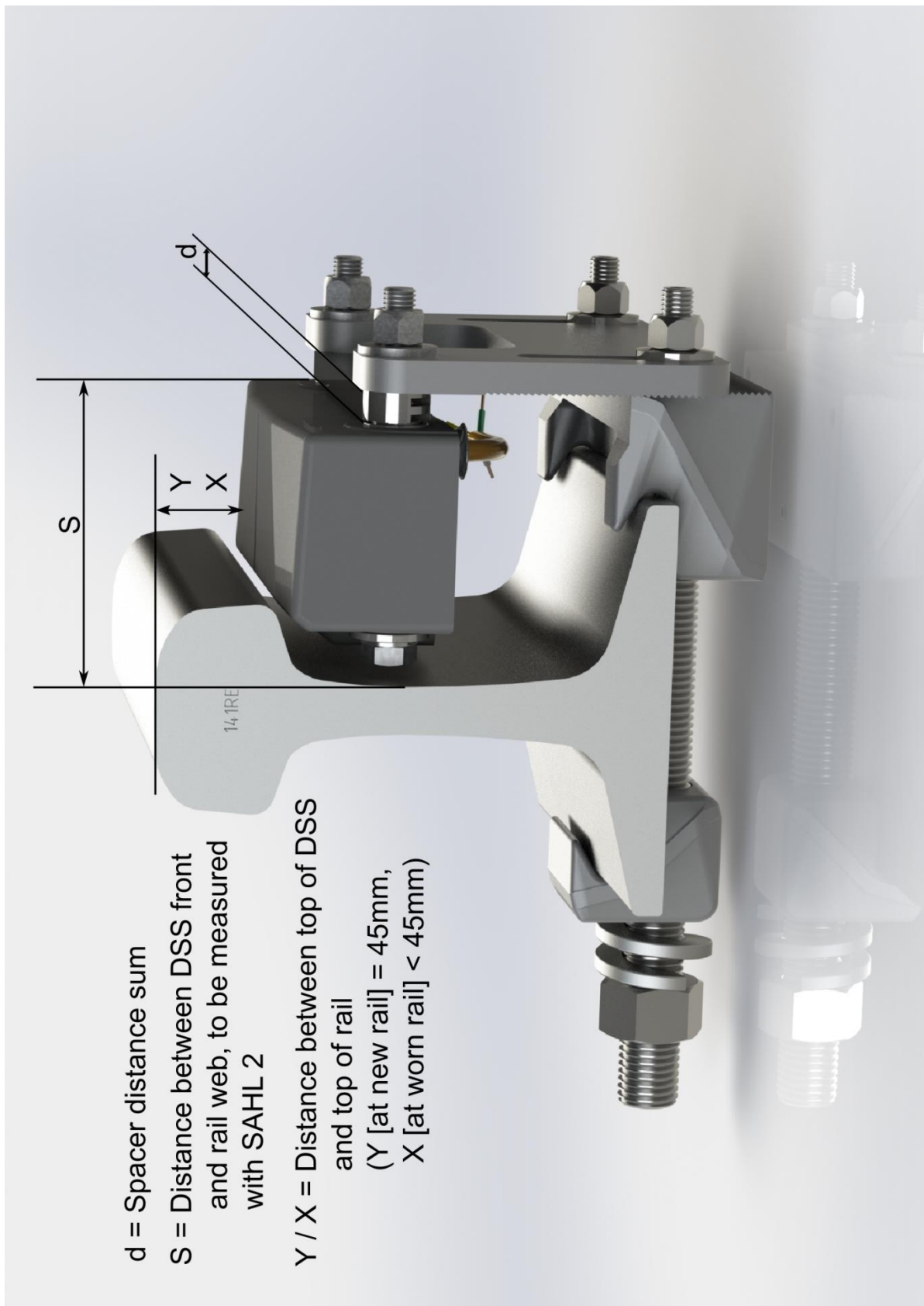

Figure 11: Installation Drawing11

### 3.7 Rail profile list





The following values are preliminary and still being tested. Therefore, this table is constantly being adjusted.

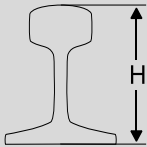

The SSK can not be used for new rails with a height below 149 mm!

For new rails with a height of 158 mm or more, an installation in the "bottom" position is possible.

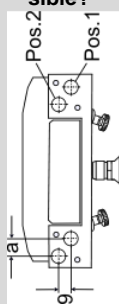
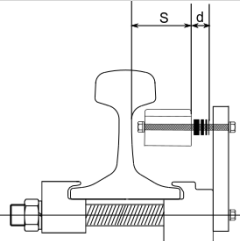
				Type of DSS	2N59-1R-250-xx	2N59-1R-250-xx	All
Identify rail profile				Specified height	SSK8	SSK8	distance DSS front edge to the rail web
					spacer plates 1, 2, 4 mm 	installation position / Lowering of position possible? 	
new rail				H	d	Y = Yes N = No	S
Field of Application	weight	indication		[mm]	[mm]		[mm]
		Norm	specific				
USA Canada	45 kg/m		ARA A 90	142.88	Installation not possible	N N	-----
Vietnam China	45 kg/m	GB258 5-81	VRC 43 P 43	140.00	Installation not possible	N N	-----
Suisse	46 kg/m	46E1	SBB I	145.00	Installation not possible	N N	-----
Nether-lands	47 kg/m	46E3	NP 46	142.00	Installation not possible	N N	-----
Australia	47 kg/m	ARTC	47 kg	141.30	Installation not possible	N N	-----
Austria	48 kg/m		S 48U	149.00	Only "top" installation	N N	-----
Germany Austria	49 kg/m	49E1	S 49 Form B	149.00	Only "top" installation	Y N	92 (±0.5) -----

Category: Installation instructions  
 Group/Type: Wheel sensor clamp SSK8  
 Item Number: 2-EL-83183-00-EN-03

				Type of DSS	2N59-1R-250-xx	2N59-1R-250-xx	All
Identify rail profile				Specified height	SSK8	SSK8	distance DSS front edge to the rail web
USA Canada	50 kg/m	AREA 100	100 RE	152.40	Only "top" installation	Y	94.0
						N	-----
USA Canada	50 kg/m	ASCE 100	100 LB	146.05	Installation not possible	Y	
						N	-----
Belgium	50 kg/m	50E2	EB 50T	151.00	Only "top" installation	Y	
						N	-----
Sweden	50 kg/m	50E3	BV 50 SJ 50	155.00	Only "top" installation	Y	
						N	-----
Germany	50 kg/m	50E4	UIC 50	152.00	Only "top" installation	Y	
						N	-----
France Luxembourg Portugal	50 kg/m	50E6	U50	153.00	Only "top" installation	Y	
						N	-----
Vietnam	50 kg/m		P 50	152.00	Only "top" installation	Y	
						N	-----
China	52 kg/m	GB258 5-81	VRC 50 S 50	152.00	Only "top" installation	Y	
						N	-----
USA Canada	53 kg/m	Dudley	Dudley 105	152.40	Only "top" installation	Y	
						N	-----
Australia	53 kg/m	ARTC	53 kg	157.10		Y	
						Y	
Suisse Austria Germany	54 kg/m	54E2	SBB IV UIC 54E Form C	161.00		Y	
						Y	
Suisse Germany Finland	55 kg/m	54E1	SBB III UIC 54 K54	159.00		Y	
						Y	
Germany	55 kg/m	54E4	S 54	154.00	Only "top" installation	Y	92 (±0.5)
						N	-----
USA Canada	56 kg/m	AREA 112	112 RE	168.28		Y	
						Y	
Great Britain	56 kg/m	56E1	BS 113 A	158.75		Y	
						Y	

Category: Installation instructions  
 Group/Type: Wheel sensor clamp SSK8  
 Item Number: 2-EL-83183-00-EN-03



				Type of DSS	2N59-1R-250-xx	2N59-1R-250-xx	All
Identify rail profile				Specified height	SSK8	SSK8	distance DSS front edge to the rail web
USA Canada	57 kg/m	AREA 115	115 RE	168.28		Y	94 (± 0.5)
						Y	
USA Canada	59 kg/m	AREA 119	119 RE	173.04		Y	
						Y	
Germany Belgium Suisse Austria	60 kg/m	60E1, 60E2	UIC 60 E2 SBB VI Form VII	172.00	7.00	Y	94 (± 0.5)
						Y	
Australia	60 kg/m	ARTC	60 kg	170.00		Y	
						Y	
USA Canada	61 kg/m	Chessi	CB 122	172.21		Y	
						Y	
China	61 kg/m	GB258 5-81	VRC 60 S 60	176.00		Y	
						Y	
USA Canada	64 kg/m	Dudley	Dudley 127	177.80		Y	
						Y	
USA Canada	65 kg/m		130 RE 130 PS 130 LB-A 130 LB-B	171.45		Y	
						Y	
Russia Finland	65 kg/m	GOST	R 65-2 P 65	180.00		Y	
						Y	
USA Canada	66 kg/m	AREA 132	132 RE	180.98		Y	94 (± 0.5)
						Y	
USA Canada	66 kg/m	AREA 133	133 RE	179.39		Y	
						Y	
USA Canada	68 kg/m	AREA 136	136 RE	185.74		Y	
						Y	
Australia	68 kg/m	ARTC	68 kg	185.70		Y	
						Y	
USA Canada	70 kg/m	AREA 140	140 RE	185.74	10.00	Y	94 (± 0.5)
						Y	
USA	70 kg/m		141 RE	188.91		Y	94 (± 0.5)



Category: Installation instructions

Group/Type: Wheel sensor clamp SSK8

Item Number: 2-EL-83183-00-EN-03

				Type of DSS	2N59-1R-250-xx	2N59-1R-250-xx	All
Identify rail profile				Specified height	SSK8	SSK8	distance DSS front edge to the rail web
Canada		AREA 141				Y	
China	75 kg/m	GB258 5-81	VRC 75 S 50	192.00		Y	
						Y	

Table 4: Excerpt From The Rail Profile List4

## 4 Maintenance of the SSK8

The following operations have to be done in the intervals defined in the following table:

In- dex	Inspection Activity	Inspection Intervals
1.	<u>Visual inspection</u> <ul style="list-style-type: none"><li>• for mechanical damages</li><li>• check for tight fit without gaps/ (do not loosen the DSS!)</li></ul>	18 months
2.	<u>Loosening of the bolts</u> <ul style="list-style-type: none"><li>• Check the tightening torque of the fixing bolts of the DSS to be 50 (<math>\pm</math> 5) Nm</li><li>• Check the tightening torque of the counter holder to be 135 (<math>\pm</math> 15) Nm</li></ul>	18 months

Table 5: Inspection Activities

Item Number: 2-EL-83183-00-EN-03



# Pintsch Tiefenbach

## A Schaltbau Company

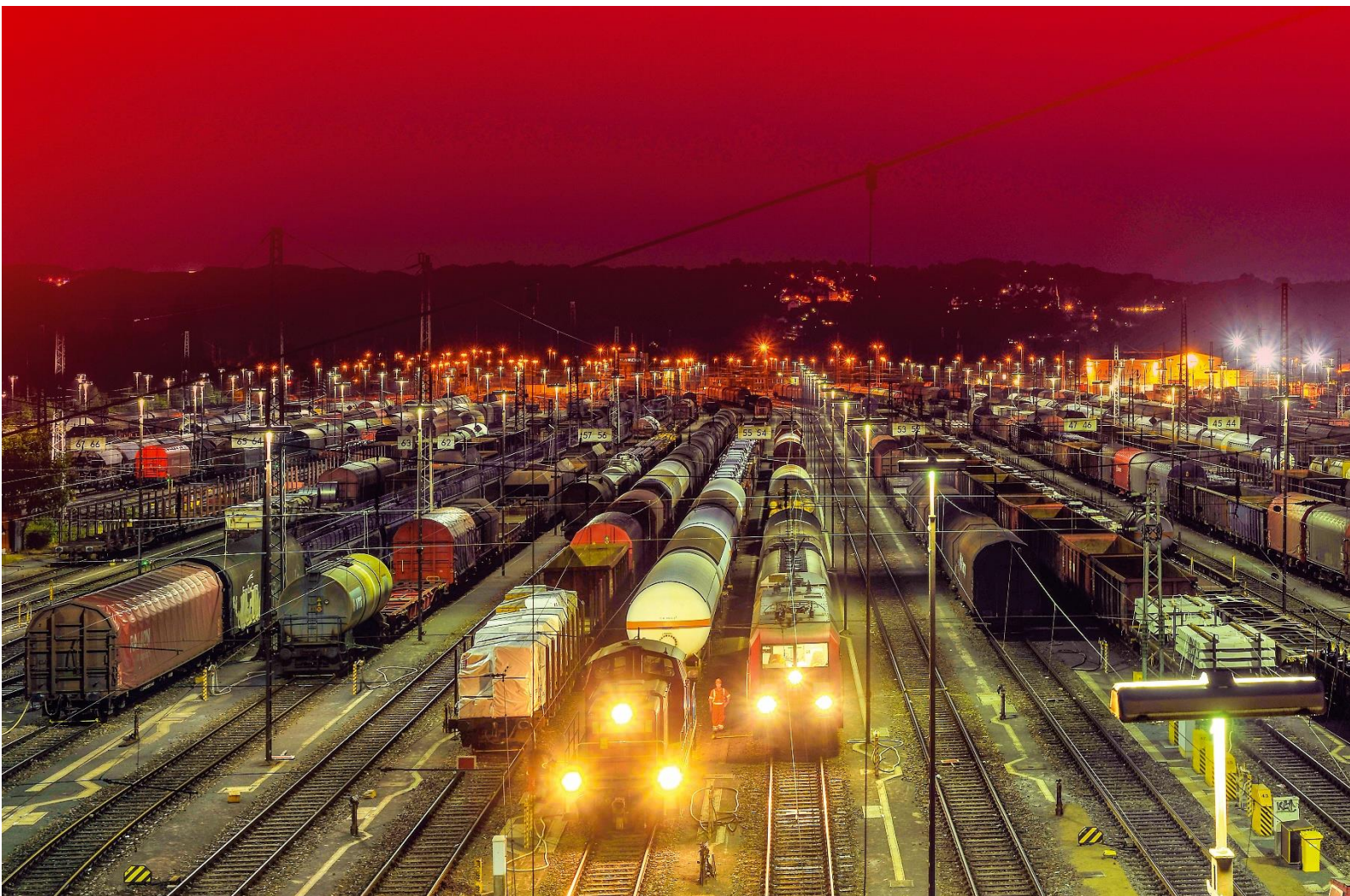

Head office: PINTSCH TIEFENBACH GmbH  
Beisenbruchstr. 10  
D-45549 Sprockhövel

Phone +49 (0) 23 24/38 03-0  
Fax +49 (0) 23 24/38 03-114

[info@pintschtiefenbach.de](mailto:info@pintschtiefenbach.de)  
[www.pintschtiefenbach.de](http://www.pintschtiefenbach.de)

Branch office: PINTSCH TIEFENBACH US Inc.  
810 Skyline Drive  
US-Marion, Illinois 62959

Phone: +1 618 993 8513  
Fax: +1 618 993 8403

[info@pintschtiefenbach.us.com](mailto:info@pintschtiefenbach.us.com)  
[www.pintschtiefenbach.us.com](http://www.pintschtiefenbach.us.com)